

BELDEN

SENDING ALL THE RIGHT SIGNALS®

LOCKING BNC INSTALLATION INSTRUCTIONS

Connector P/N: 1694ABHDL,
1695ABHDL, 1505ABHDL,
1506ABHDL, 1855ABHDL,
179DTBHDL

Compression tool: BBCOMT
Tip Required: None
Preparation tool: BBRGST or
BBRGBST

Step 1

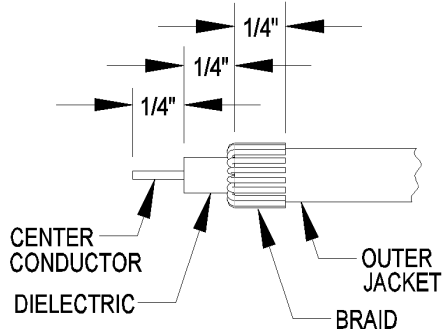

Prepare the cable according to step 1 to achieve the proper braid exposure and center conductor length. Fold the braid against the outer jacket as shown. Twist the foil tightly against the dielectric and verify there are no loose braids or foil touching the center conductor.

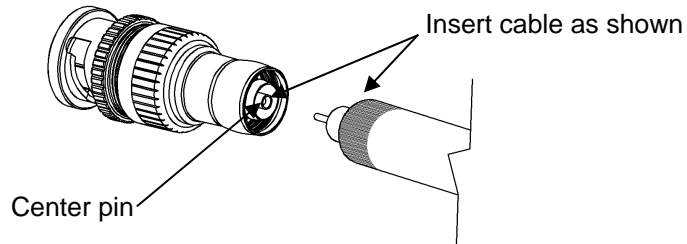

Center pin is aligned with inner ring once cable is in place

Step 2

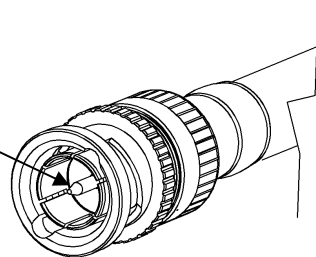

Step 3

The BBCOMT is shown with the dies in the open position, ready to receive the connector.

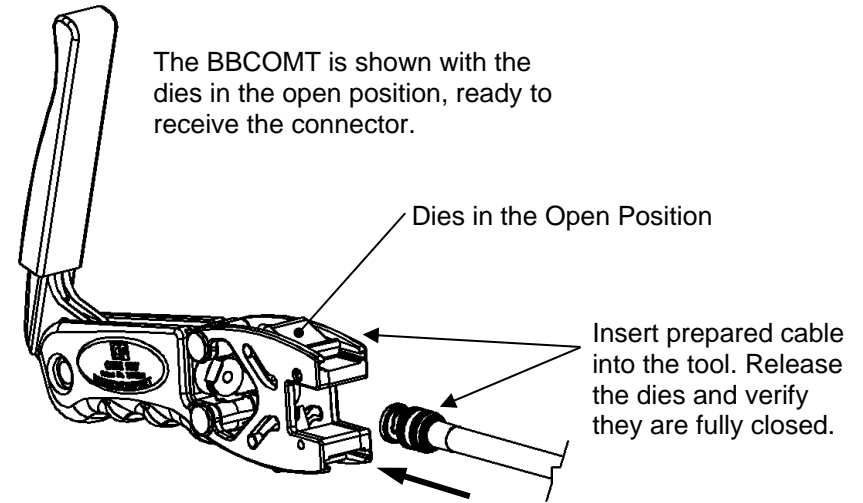

Step 4

Dies in the Closed position

With the connector positioned in the plunger head, close the handle as shown to terminate the connector.

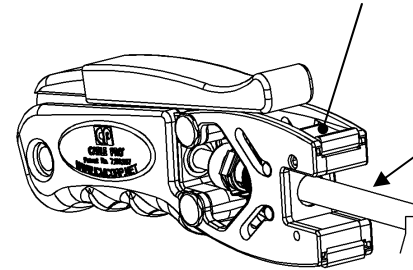

Step 5

Dies in the Open position

Open the handle, retract dies and remove the cable. Slight inward pressure on the cable can be applied to ease removal.

